



Scan to Watch
Assembly Video
or go to
antennasdirect.com
/assembly-videos



Quick Start Assembly/Installation Instructions

CLEARSTREAM™ 2 RV ON-THE-GO HDTV ANTENNA



Before beginning assembly, make sure all parts needed are present.

WARNING: Failure to follow these instructions and properly secure the antenna or any of its parts could result in antenna or preamplifier becoming separated during travel and potentially causing injury.

READ BEFORE INSTALLATION:

Before installing the antenna, make sure there is enough space when elevating mast is in the travel position.

Tools required: Medium-sized Cross Point Screwdriver, 10 mm Ratcheting Driver, and Needle-Nose Pliers.

PARTS:

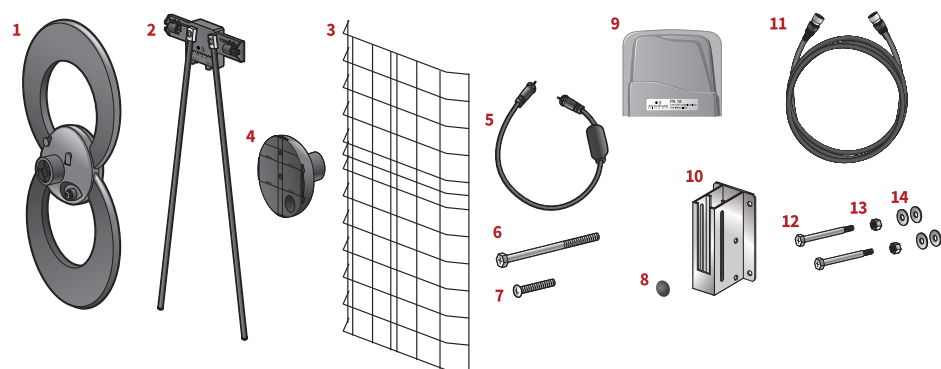

The ClearStream 2 RV Antenna comes with:

- | | |
|--|-----------------------|
| 1) Antenna Element | 10) Mast Bracket |
| 2) VHF Dipoles | 11) 36" Coaxial Cable |
| 3) Reflector | 12) 2 - 1 3/4" Screws |
| 4) Antenna Base | 13) 2 - Nuts |
| 5) 12" Coaxial Cable with Weather Boot | 14) 4 - Washers |
| 6) 3 1/2" Bolt | |
| 7) 1 1/2" Bolt | |
| 8) Rubber Bumper | |
| 9) Preamplifier | |

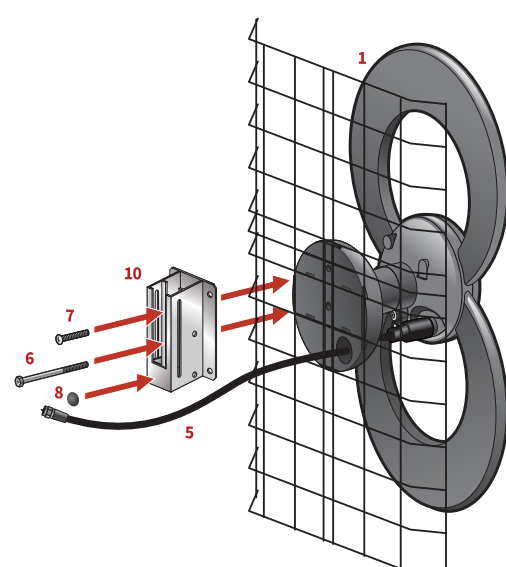
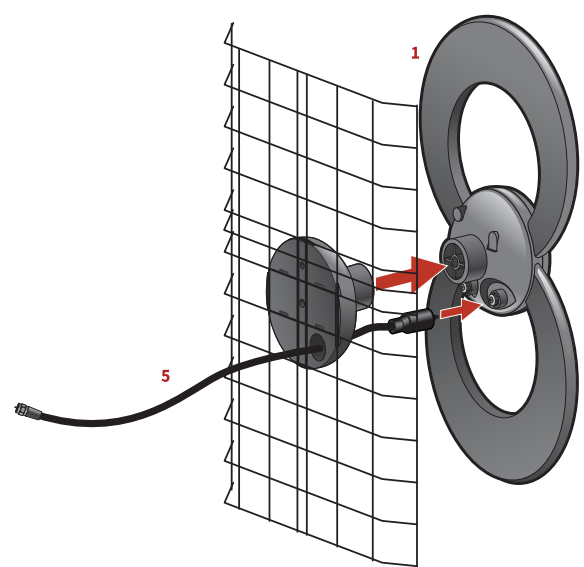
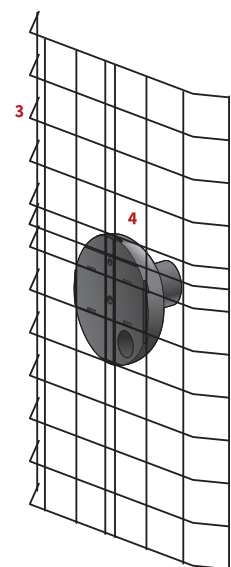

Slide the Weather Boot (5) over the connection at the base of the Antenna Element (1).

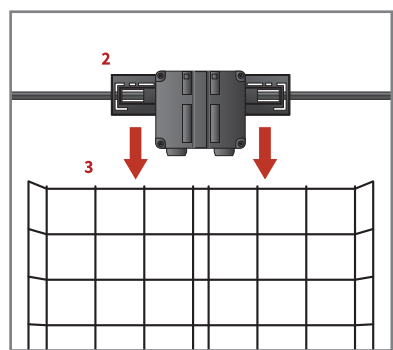

Attach the VHF Dipoles (2) to the Reflector (3) on the first and second bar. Then, push down until it snaps into place.

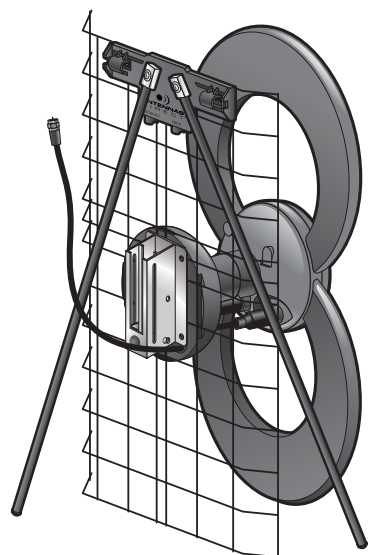

Remove the existing antenna from the elevating mast.

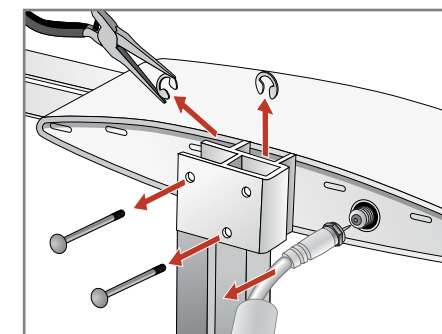

Detach the coaxial cable. Then, remove the pins and bolts.

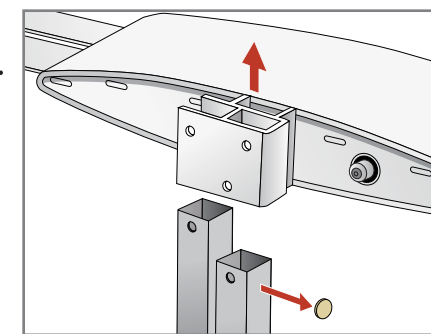

Remove the antenna and bumper pad from the mast.

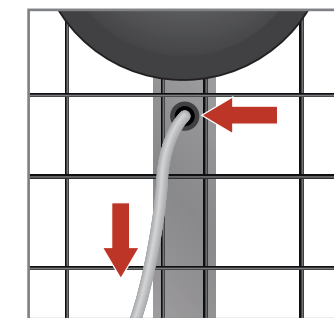

Before placing the antenna on the elevating mast, insert the existing down-lead coaxial cable through the Reflector (3) grid below the Antenna Element (1). Then, slide the Mast Bracket (10) over the mast.

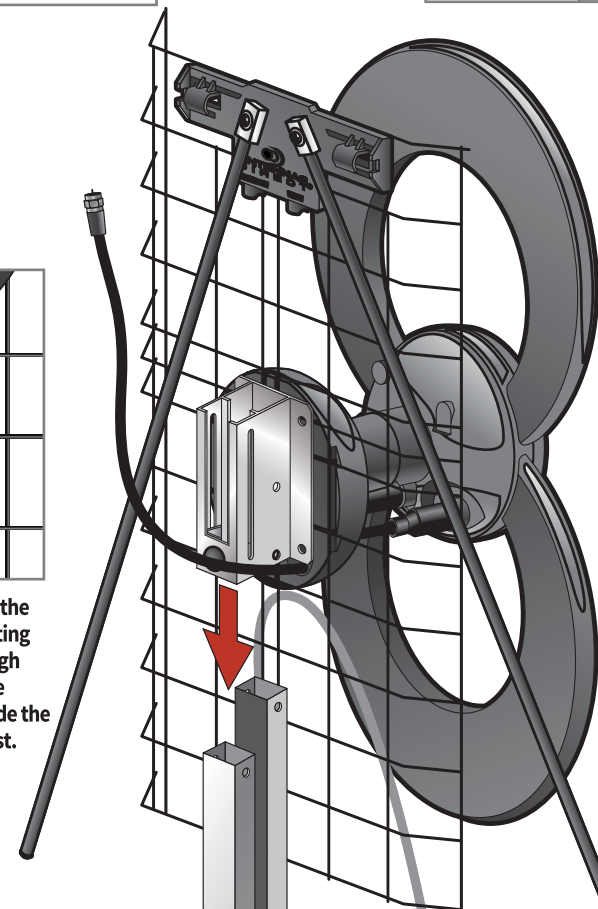

Secure the Mast Bracket (10) using the 1 3/4" Screws (12), Washers (14), and Nuts (13).

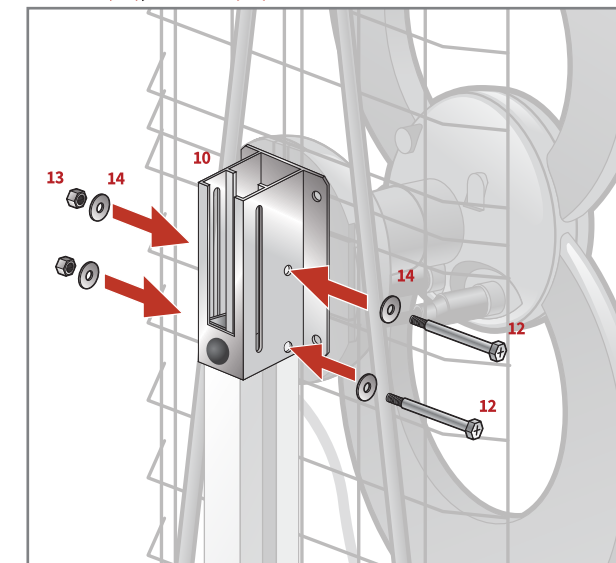

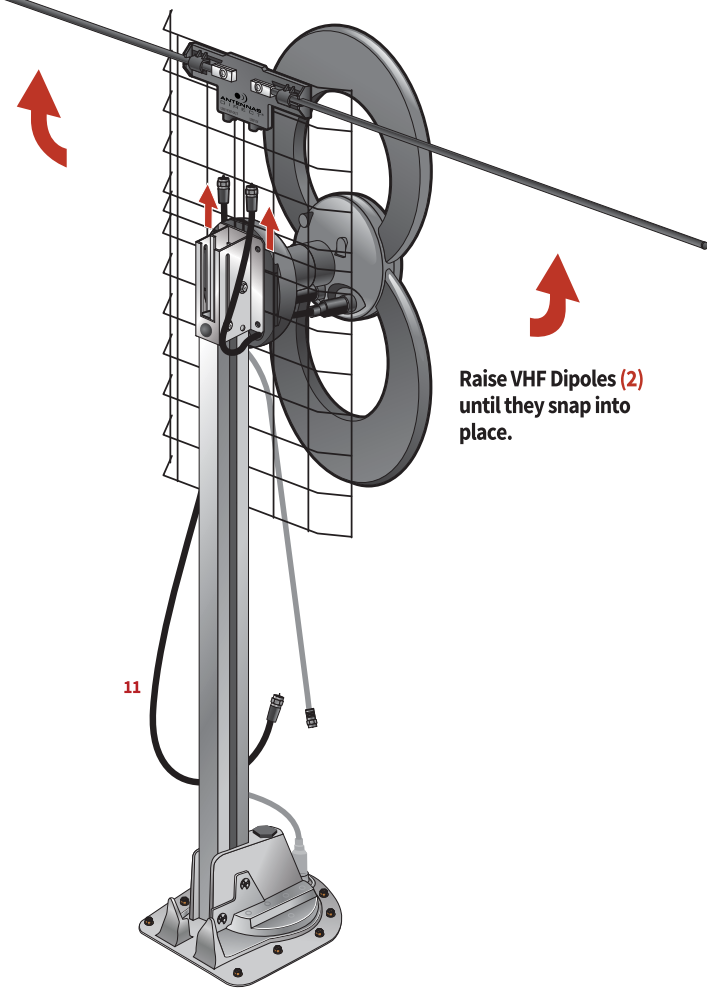

Raise VHF Dipoles (2) until they snap into place.

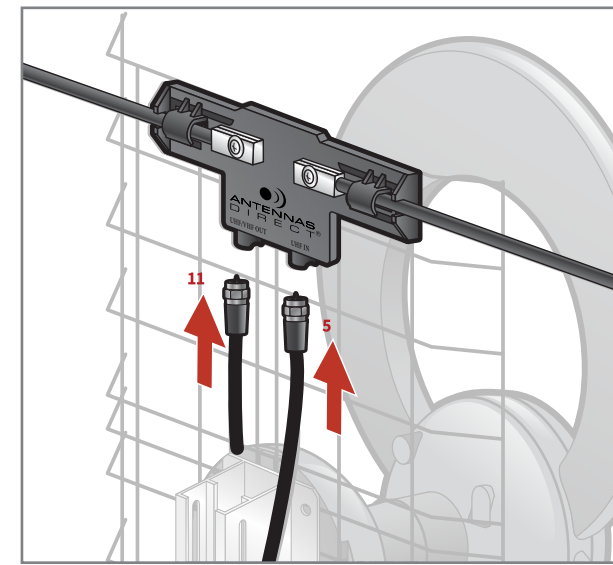

Attach the 12" Coaxial Cable (5) to the UHF IN port on the VHF Dipoles (2). Then, attach the 36" Coaxial Cable (11) to the UHF/VHF OUT port.

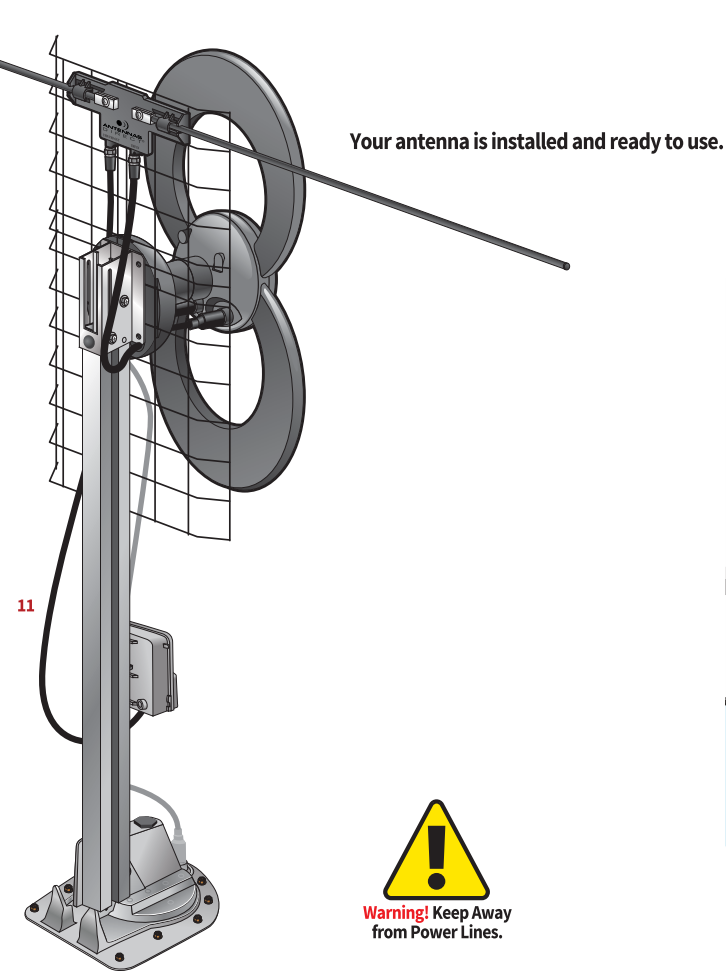

Warning! Keep Away from Power Lines.

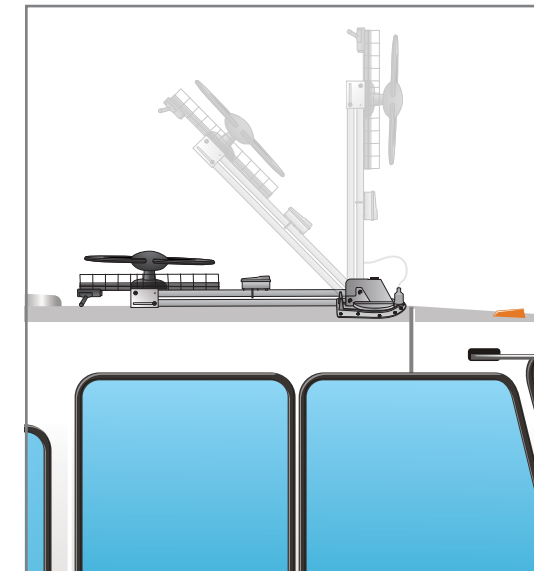

When finished using the antenna, lower the antenna into the travel position indicated by the arrow on the ceiling plate. Turn off the power supply.

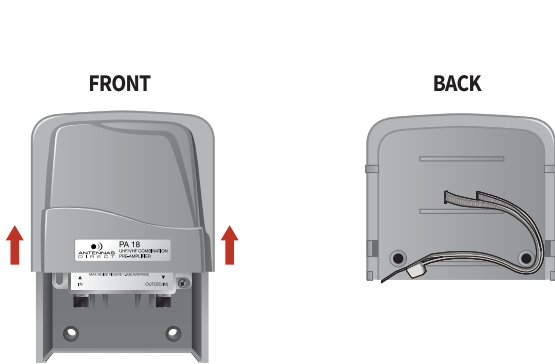

Slide the lid open to expose the Preamplifier.

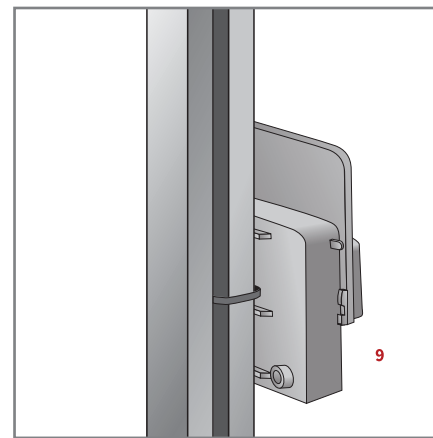

Zip-tie the Preamplifier (9) to (only) the front pole on the elevating mast.

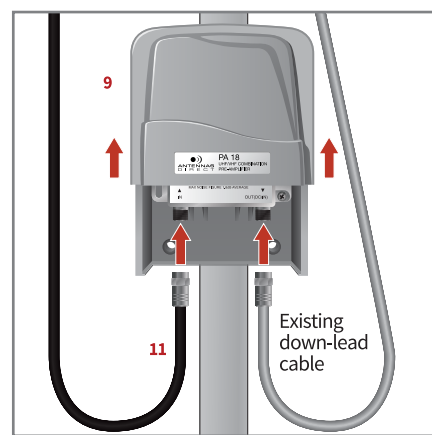

Attach Coaxial Cables to the Preamplifier (9).

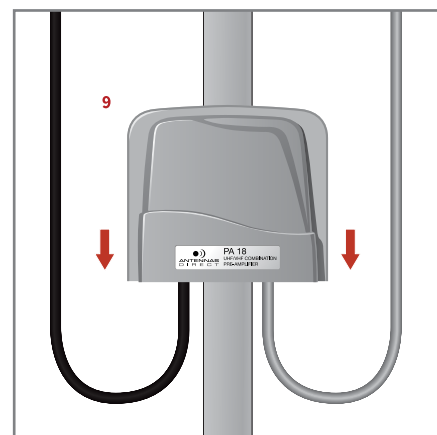

Close the lid.

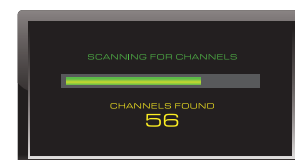
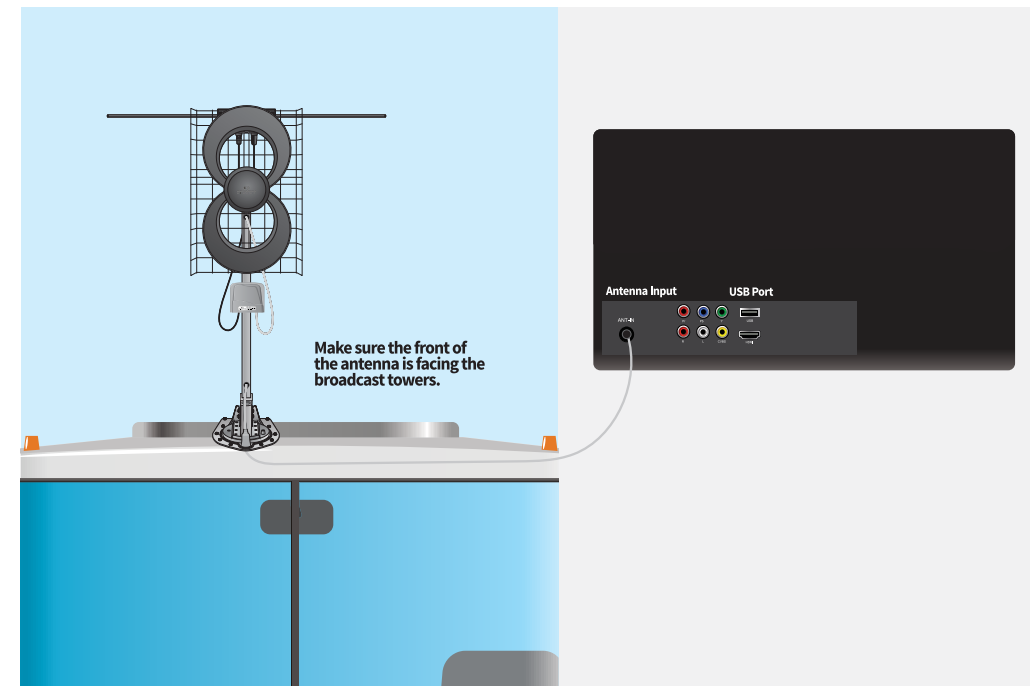

Now that you've installed your antenna, you are ready to scan for channels. See "Scanning for channels" in the troubleshooting guide.

Congratulations! You're watching HDTV for FREE! Welcome to the Antennas Direct cord-cutting family.

TROUBLESHOOTING:

1. SCANNING FOR CHANNELS: A digital TV must be programmed in order to receive digital channels. Once your antenna is installed, you must complete a channel scan, even if you have done so before installing the antenna, or if you've installed a new antenna. With the antenna in the "up" position, pull down on the elevating crank and rotate the antenna towards the largest cluster of towers in your area for the best picture and sound.

- Check parking location for obstructions before scanning for channels.
- Your TV must be set to the proper input source. Press the "Input" (or "Source") button on your remote and make sure the input is set to TV.
- Follow the instructions specific to the make and model of your television to set the signal type to "ANTENNA", "AIR", or "BROADCAST", not "Satellite".
- Go to the main menu of your TV and complete a channel scan. This could be listed as "Auto Program", "Auto Tuning", or "Auto Channel Scan". Consult the owner's manual for your specific device and more precise guidelines. You may need to rotate your antenna various times. Remember to rescan for channels every time you change the position of the antenna. Repeat as needed until channels are found.

2. Make sure the front of the antenna is facing the broadcast towers. Download the **free Antenna Point app** to your Android/iOS smartphone or tablet. Antenna Point identifies your location and allows you to view the transmitting towers in the area, along with the distance to each tower.

Problem: I'm not getting any signals.

Possible causes:

- You do not have a clear line of sight to the broadcast towers. Make certain the antenna is not aimed into physical obstacles such as a building, dense foliage, or a hill. Remember to rescan for channels every time you rotate the antenna.

2. You may have loose coaxial cable connections.

Check ALL connections for a tight fit and check all outdoor connections for moisture or corrosion.

Problem: I'm receiving every channel except for one.

Possible cause:

- You may need to rescan the TV tuner.

The channel you are not receiving may have its transmitter lower on the broadcast tower, or on a different tower than the other transmitters and your line of sight is obstructed. If it is possible to shift or move the position of your vehicle, this may improve reception.

Problem: I'm having signal breakups.

Possible cause:

- Your TV may be receiving interfering signals.

Consider rotating the antenna and rescanning for channels. If this is not successful, call our helpline or chat with us online at antennasdirect.com for an analysis of the area. We may be able to offer simple solutions.

When finished using the antenna, lower the antenna into the travel position indicated by the arrow on the ceiling plate. Turn off the power supply.

Before You Return, Call to Learn.



For Tower Locations: antennapoint.com



Input on Antenna Mode



Scanning is a Must When in Doubt, Rescan

HELPLINE: 1-877-825-5572

MODEL # C2-V-RV

Amplifier Regulatory Notice: This device complies with part 15 of the FCC Rules. Operation is subject to the following two conditions:

(1) This device may not cause harmful interference, and (2) this device must accept any interference received, including interference that may cause undesired operation. Changes or modifications not expressly approved by the party responsible for compliance could void the user's authority to operate this device.

This equipment has been tested and found to comply with the limits for a Class B Digital Device, pursuant to Part 15 of the FCC Rules. These limits are designed to provide reasonable protection against harmful interference in a residential installation.

This equipment generates, uses, and can radiate radio frequency energy and, if not installed and used in accordance with the instructions, may cause harmful interference to radio communication. However, there is no guarantee interference will not occur in a particular installation.

If this equipment does cause harmful interference to radio or television reception, which can be determined by turning the equipment off and on, the user is encouraged to try to correct the interference by one or more of the following measures:

- Reorient or relocate the antenna.
- Increase the separation between the equipment and converter box.
- Connect the equipment into an outlet on a different circuit from which the converter box is connected.
- Consult the dealer or an experienced radio/TV technician for help.

**Antennas Direct™ Inc.
Antenna Lifetime Warranty**

Antennas Direct™ Inc. warrants this product against any defects in materials or workmanship for as long as you own the product. No warranty claim will be honored unless, at the time the claim is made, you present proof of purchase from an authorized Antennas Direct™ Inc. dealer.

Antennas Direct™ Inc. will either repair or replace the defective product at no charge to you. This warranty covers parts but does not cover any costs incurred in the removal or reinstallation of the product. This limited warranty does not apply if the product is damaged or fails due to: misuse, improper installation, abuse, and modification of the product as originally manufactured by Antennas Direct.

Antennas Direct™ Inc. will not assume any liabilities for any other warranties expressed or implied by any other person. The foregoing shall be the sole and exclusive remedy of any person, whether in contract, tort, or otherwise, and Antennas Direct™ Inc. shall not be liable for incidental or consequential damage or commercial loss, or for any other loss or damage, as set forth above.

16388 Westwoods Business Park, Ellisville, MO 63021, USA

©Antennas Direct, Inc.
Model # C2-V-RV
10.2024

TV RECEPTION CAN BE AFFECTED BY OBSTRUCTIONS OR DISTANCE BETWEEN YOUR HOME AND BROADCAST TOWERS.



Call us toll-free for technical assistance at 1-877-825-5572 or contact support@antennasdirect.com

FIND TV CHANNELS, AIM YOUR ANTENNA

antenna point

DOWNLOAD OUR FREE APP